

# SERVER®

• E S S E N T I A L S •

## Specialty Warmer IntelliServ® Food Pan Warmer

SPECIFICATION SHEET

### FAST FACTS

The IntelliServ® Warmer is an end-operated, water-bath warmer that is ideal for effective kitchen placement while digital temperature control ensures accurate heating and holding – to the last serving.

### APPLICATIONS

- Great for difficult to hold products such as chocolate, alfredo and hollandaise sauce that require precise temperature control
- Open design adapts to menu changes for topping, finishing or plating with ladles, pumps or squeeze bottles

### DETAILS

- Warm up to 6-quarts in 8-in of countertop space
- Digital temperature control ensures accurate holding of delicate soups and sauces; display provides instant feedback of heat setting and status
- Modular design holds (1) 1/3 -, (2) 1/6 - or (3) 1/9 -size food pans up to 6 in deep
- NSF listed rethermalizer – quickly heats to a safe serving temperature before bacteria has an opportunity to grow
- Cool-touch rim protects staff from typical hot-zone risks when switching pans out



Shown: 1/6-pans and ladles



Shown: 1/6-pans and FP-1/6 pumps



IS-1/3 86090



Smart food warmers  
serve fresh all day long.  
Adapt for topping, finishing or  
plating with ladles, pumps  
or high-temp squeeze bottles.

Everything you need and more, in less.

## INTELLISERV® WARMER MODEL: IS-1/3

Server IntelliServ® Warmer model IS-1/3 is an end-operated, countertop warmer. This water-bath, food-pan warmer with digital temperature control (F°/C°) is constructed of stainless steel with a thermoset plastic water vessel and cast aluminum heat plate. This NSF-listed rethermalizer holds up to 6 quarts in (1) 1/3-size, (2) 1/6-size, or (3) 1/9-size food pans, 6 in deep and can be configured to serve with ladles or pumps. NEMA 5-15P plug with 72 in power cord. 2-year warranty.

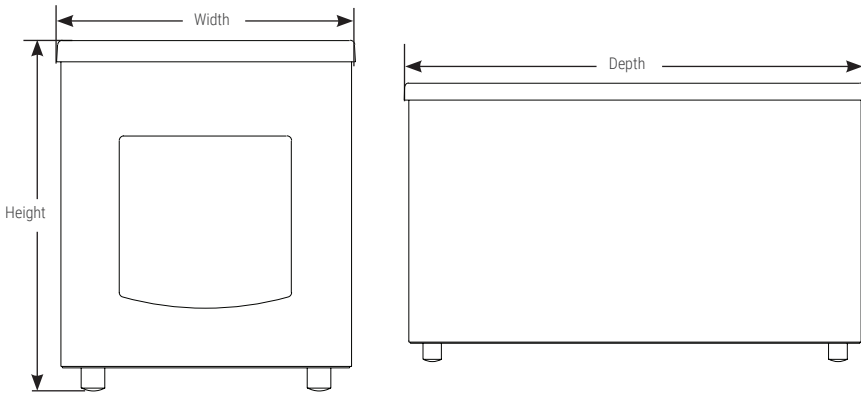

## FOOD PAN WARMER

order amt	model/item	description	capacity	dims (H x W x D)	plug	electrical	watts	weight
<input type="checkbox"/>	<a href="#">IS-1/3</a> <a href="#">86090</a>	1/3-size food pan warmer, countertop	up to 6 qt; using 1/3-size, 6" deep food pan	9 5/16" x 7 15/16" x 15 3/8"		120 V AC 4.2 A	500	17 lb

## ACCESSORY ITEMS

order amt	item	description	order amt	item	description
<input type="checkbox"/>	<a href="#">86312</a>	FP-1/6 pump, 1 oz (fits 6" deep pan)	<input type="checkbox"/>	<a href="#">90089</a>	1/6-size, 6" deep, 2 3/4 qt pan
<input type="checkbox"/>	<a href="#">87213</a>	stainless steel ladle, 6", 1 oz	<input type="checkbox"/>	<a href="#">90094</a>	1/6-size pan lift-off lid
			<input type="checkbox"/>	<a href="#">90106</a>	1/9-size, 4" deep, 1 1/8 qt pan

SERVE FRESH ALL DAY LONG WITH AN INTELLISERV® FOOD PAN WARMER  
 SERVER-PRODUCTS.COM | 800.558.8722 | 262.628.5600